

May 2013

Dynamic Modeling and Analysis of Propulsion effect of 3 DoF robot

Ahmet Shala

University for Business and Technology, ahmetshala_2000@yahoo.com

Xhevahir Bajrami

Vienna University of Technology, xhevahirbajrami@hotmail.com

Follow this and additional works at: <https://knowledgecenter.ubt-uni.net/ijbte>



Part of the [Computer Sciences Commons](#), and the [Engineering Commons](#)

Recommended Citation

Shala, Ahmet and Bajrami, Xhevahir (2013) "Dynamic Modeling and Analysis of Propulsion effect of 3 DoF robot," *International Journal of Business and Technology*. Vol. 1 : Iss. 2 , Article 3.

DOI: 10.33107/ijbte.2013.1.2.03

Available at: <https://knowledgecenter.ubt-uni.net/ijbte/vol1/iss2/3>

This Article is brought to you for free and open access by the Publication and Journals at UBT Knowledge Center. It has been accepted for inclusion in International Journal of Business and Technology by an authorized editor of UBT Knowledge Center. For more information, please contact knowledge.center@ubt-uni.net.

Dynamic Modeling and Analysis of Propulsion effect of 3 DoF robot

Ahmet Shala¹, Xhevahir Bajrami²

¹University of Prishtina, Faculty of Mechanical Engineering

¹University for Business and Technology

²Vienna University of Technology

Abstract. Dynamical Modeling of robots is commonly first important step of Modeling, Analysis and Control of robotic systems. This paper is focused on using Denavit-Hartenberg (DH) convention for kinematics and Newton-Euler Formulations for dynamic modeling of 3 DoF - Degree of Freedom of 3D robot. The process of deriving of dynamical model is done using Software Maple. Simulations are done using Matlab/Simulink for analysis of propulsion effect under Earth gravity when First Link rotates with 1000 rpm, second Link can move free in vertical direction and Third Link can rotates free around their rotations axle. Simulations results shows very good propulsion of proposed 3 DoF robot. Results are verified-compared with constructed model of 3 DoF robot using Working Model 3D Software.

Keywords: Kinematics, dynamics, robot, propulsion.

1. Dynamical modeling of 3 DOF Robot

Dynamics is a huge field of study devoted to studying the forces required to cause motion. The dynamic motion of the manipulator arm in a robotic system is produced by the torques generated by the actuators. This relationship between the input torques and the time rates of change of the robot arm components configurations, represent the dynamic modeling of the robotic system which is concerned with the derivation of the equations of motion of the manipulator as a function of the forces and moments acting on. So, the dynamic modeling of a robot manipulator consists of finding the mapping between the forces exerted on the structures and the joint positions, velocities and accelerations. A good model has to satisfy two conflicting objectives. It must include enough detail to represent the real behavior of the robot with sufficient accuracy, and it should permit an efficient, stable evaluation not only of the model equations but also of their derivatives that are needed in optimization.

The availability of the dynamic model is very useful for mechanical design of the structure, choice of actuators, determination of control strategies, and computer simulation manipulator motion.

A robot manipulator is basically a positioning device. To control the position we must know the dynamic properties of the manipulator in order to know how much force to exert on it to cause it to move: too little force and the manipulator is slow to react; too much force and the arm may crash into objects or oscillate about its desired position.

Deriving the dynamic equations of motion for robots is not a simple task due to the large number of degrees of freedom and nonlinearities present in the system. This part is concerned with the development of the dynamic model for 3 Dof robot and their kinematics and dynamics equations.

2. Dof robot structure and coordinate systems

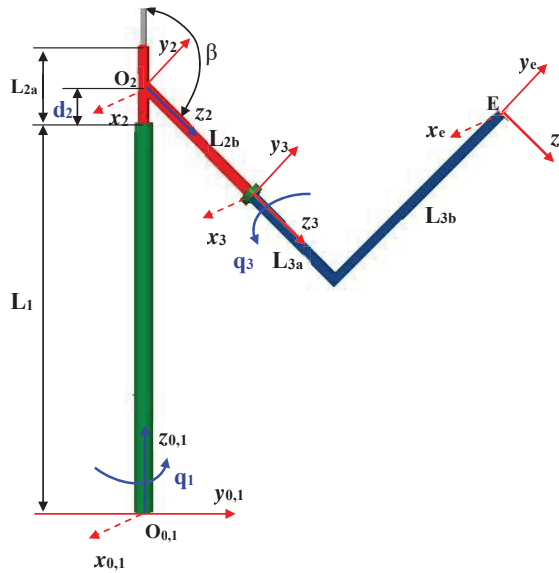

Figure 1a. Symbolic representation - Axes rotations for Denavit-Hartenberg parameters

From Figure 1a, can be created Table 1 of Denavit-Hartenberg parameters for 3 DoF robot

Table 1. Denavit-Hartenberg parameters for 3 DoF robot

Link #	a_i	α_i	d_i	θ_i
1	0	0	d_1	q_1^*
2	0	α_2	d_2^*	0
3	0	0	L_{3a}	q_3^*

* Joint variable

Denavit-Hartenberg transformation matrix for adjacent coordinate frames, i and $i - 1$.

$$A_i = \begin{bmatrix} \cos(\alpha_i) \cos(\alpha_i) \sin(\alpha_i) & \sin(\alpha_i) \sin(\alpha_i) a_i \cos(\alpha_i) & 0 & 0 \\ \sin(\alpha_i) & \cos(\alpha_i) \cos(\alpha_i) & \sin(\alpha_i) \cos(\alpha_i) a_i \sin(\alpha_i) & 0 \\ 0 & \sin(\alpha_i) & \cos(\alpha_i) & d_i \\ 0 & 0 & 0 & 1 \end{bmatrix}$$

Orthogonal rotation matrix R_i which transforms a vector in the i -th coordinate frame to a coordinate frame which is parallel to the $(i-1)$ -th coordinate frame is first 3x3 sub-matrices of A_i :

$$R_i = \begin{bmatrix} \cos(\alpha_i) \cos(\alpha_i) \sin(\alpha_i) & \sin(\alpha_i) \sin(\alpha_i) & 0 \\ \sin(\alpha_i) & \cos(\alpha_i) \cos(\alpha_i) & \sin(\alpha_i) \cos(\alpha_i) a_i \\ 0 & \sin(\alpha_i) & \cos(\alpha_i) \end{bmatrix}$$

for $i=1,2, \dots, N$, where $R_{N01} = E = \text{diag}(1)$

3. Dynamic Equations – Newton-Euler Formulation

Dynamics of robot is the study of motion with regard to forces (the study of the relationship between forces/torques and motion). A dynamic analysis of a manipulator is useful for the following purposes: 1- It determines the joint forces and torques required to produce specified end-effector motions (the direct dynamic problem).

2- It produces a mathematical model which simulates the motion of the manipulator under various loading conditions (the inverse dynamic problem) and/or control schemes.

3- It provides a dynamic model for use in the control of the actual manipulator.

Dynamic modelling of mechanical structures can be a complex problem. In robotics, more specifically, in manipulators, there are two methodologies used for dynamic modelling: a) *Newton-Euler formulation* b) *Lagrange-Euler formulation*.

The Newton-Euler formulation [1] shown in equations (1)-(9) computes the inverse dynamics (ie., joint torques/forces from joint positions, velocities, and accelerations) bases on two sets of recursions: the *forward* and *backward* recursions. The forward recursions (1)-(3) transform the kinematics variables from the base to the end-effector. The initial conditions (for $i=0$) assume that the manipulator is at rest in the gravitational field. The backward recursions (4)-(9) transform the forces and moments from the endeffector to the base, and culminate with the calculation of the joint torques/forces. Angular velocity of the i -th coordinate frame

$$\begin{aligned} \omega_i^T &= R_{i-1}^T \omega_{i-1} + z_0 \dot{\theta}_i \begin{bmatrix} 0 \\ 0 \\ 1 \end{bmatrix} \text{ if joint is rotational} \\ \omega_i &= R_{i-1} \omega_{i-1} \text{ if joint is translational} \end{aligned} \tag{1}$$

where: $z_0 = [0 \ 0 \ 1]^T$

Angular acceleration of the i -th coordinate frame

$$\begin{aligned} \alpha_i^T &= R_{i-1}^T \alpha_{i-1} + \dot{\omega}_i + z_0 \ddot{\theta}_i \begin{bmatrix} 0 \\ 0 \\ 1 \end{bmatrix} \text{ if joint is rotational} \\ \alpha_i &= R_{i-1} \alpha_{i-1} \text{ if joint is translational} \end{aligned} \tag{2}$$

Linear acceleration of the i -th coordinate frame

$$\begin{aligned} a_i^T &= R_{i-1}^T v_{i-1} + \dot{\omega}_i \times p_i + \omega_i \times (\omega_i \times p_i) \\ & \text{if joint is rotational } v_i = R_{i-1}^T v_{i-1} + z_0 \dot{d}_i \\ & 2\omega_i \times (z_0 \dot{d}_i) \text{ if joint is translational} \\ & \omega_i \times (i \times p_i) + \omega_i \times (i \times p_i) \end{aligned} \tag{3}$$

where: $p_i = [a_i \ d_i \ 0]^T$ $d_i = \sin(\theta_i)$ $d_i = \sin(\theta_i)$ is position of the i -th coordinate frame with respect to the $(i -$

1)-th coordinate frame.

Initial conditions: $\dot{\theta}_0 = \dot{\theta}'_0 = v_0 = 0$;

Gravitational acceleration: $v'_0 = [g_x \ g_y \ g_z]^T$.

Linear acceleration of the centre-of-mass of link i $a_i = \ddot{s}_i + \ddot{\theta}_i s_i + \dot{\theta}_i^2 s_i$ where: s_i is position of centre-of-mass of link i (4)

Net force exerted on link i : $F_i = m_i a_i$ (5)

Net moment exerted on link i $N_i = I_i \ddot{\theta}_i + \dot{\theta}_i^2 I_i s_i$ (6)

$$I_i = \begin{bmatrix} I_{ixx} & 0 & 0 \\ 0 & I_{iyy} & 0 \\ 0 & 0 & I_{izz} \end{bmatrix}$$

where $I_i = \begin{bmatrix} I_{ixx} & 0 & 0 \\ 0 & I_{iyy} & 0 \\ 0 & 0 & I_{izz} \end{bmatrix}$

$$I_i = \begin{bmatrix} I_{ixx} & 0 & 0 \\ 0 & I_{iyy} & 0 \\ 0 & 0 & I_{izz} \end{bmatrix}$$

I_i is moment of inertia tensor of link i about the centre-of-mass of link i (parallel to the i -th coordinate frame), with only principal inertias I_{ixx} , I_{iyy} and I_{izz} . Because of symmetry of link frames, cross-inertias can be used zero. Force exerted on link i by link $i - 1$:

$$f_i = R_i^T p_{i-1} + F_i \quad (7)$$

Moment exerted on link i by link $i - 1$

$$n_i = R_i^T n_{i-1} + p_i \times f_i + N_i + s_i \times F_i \quad (8)$$

Joint torque/force at joint i :

$$\tau_i = \begin{cases} n_i^T (R_i^T p_{i-1} + z_0) & \text{if joint is rotational} \\ f_i & \text{if joint is translational} \end{cases} \quad (9)$$

Modeling of 3 DoF robot is done using Maple 15 software, equations are converted for Matlab use.

4. Simulation results of existence or non-existence of the desired propulsion effect!

For analysis of existence or non-existence of propulsion is done test as in view. Link 3 (L-form) rotates free from vertical initial position. One part of Link 2 is vertical and second part is under 135° with verticals. Link 2 can move free up-down and is supported free on Link 1.

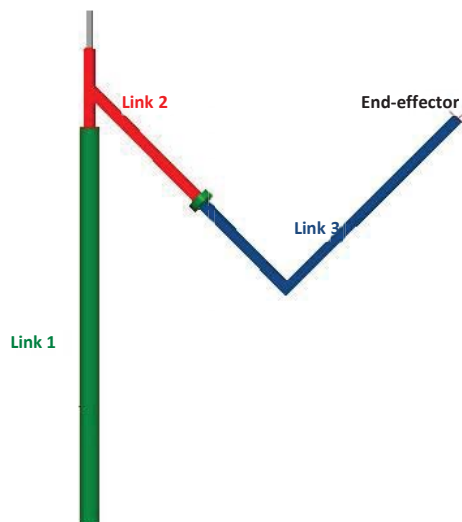

Figure 1b. Robot 3 DoF in initial position.

From the simulation based on previous conditions, in Figure 2 are represented diagram of Contact Force between Link 2 and Link 1 when Link 3 rotates free from initial position (0.1 deg deviated because of theoretical stability) and diagram of orientation of Link 3 respectively q_3 .

Main dimensions of robot

Link masses: $m_1=10$ kg, $m_2=10$ kg, $m_3=15$ kg.

Link lengths: $L_1 = d_1=1.0$ m, $L_{2a}=2 \square d_2=0.2$ m, $L_{2b}=0.4$ m, $L_{3a}=0.3$ m, $L_{3b}=d_3=0.6$ m

Figure 2. Contact Force between Link 2 and Link 1 and orientation q_3 of Link 3.

From Figure 2 can be seen that Contact Force has its maximum $F_{c2max}=392.16$ N for $q_3=180^\circ$.

5. Simulation of propulsion of dynamical model of 3d of robot

- Angle between two parts of Link 2 is fixed to 45° ;

- Link 3 starts in vertical position (down normal to x_0-y_0 plane) and swings free
- Link 2 is free supported on Link 1
- Link 1 is turned up to 1000 rpm
- Steel is assumed for cylinder/prism masses and moments of inertia.

Main characteristic of this Case: start position of Link 3, $q_3 = \pi = 180^\circ$

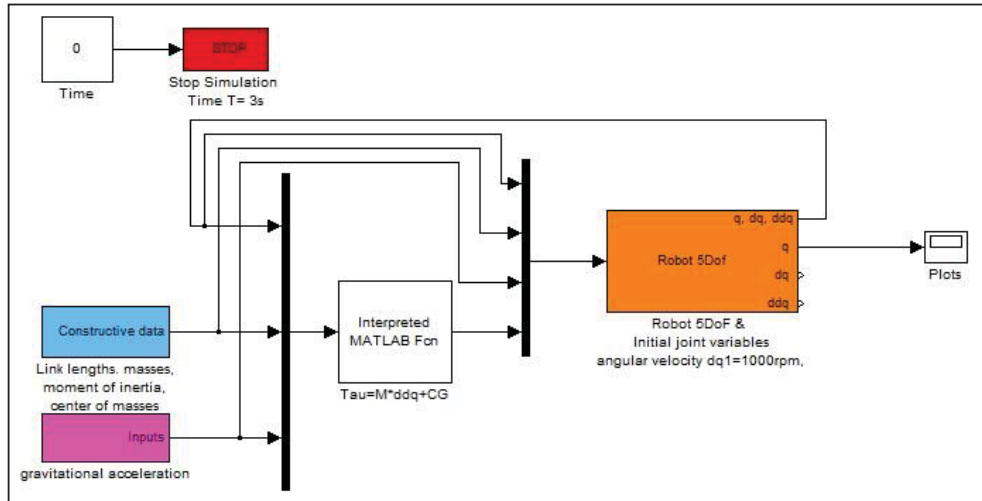

Figure 3. Simulation scheme of robot, propulsion effect for initial position of Link 3 under $q_3=180^\circ$

Propulsion is result of fast rotation of Link 1, 1000 rpm, and rotation-oscillation of Link 3, which results from contact force between Link 2 and Link 1, only for the time when these two Links are in contact, when Link 2 starts to move up ($d_2 > 1.1$) contact force is zero.

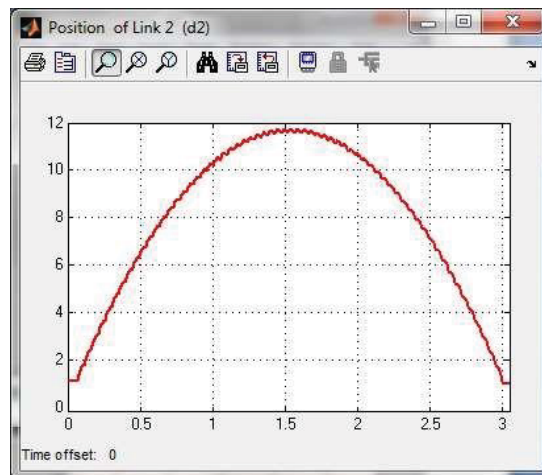

Figure 4. Vertical movement of Link 2

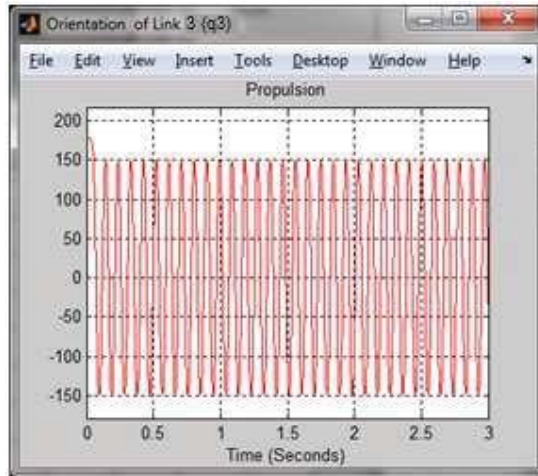

Figure 5. Orientation of Link 3 around its rotation axe, q_3

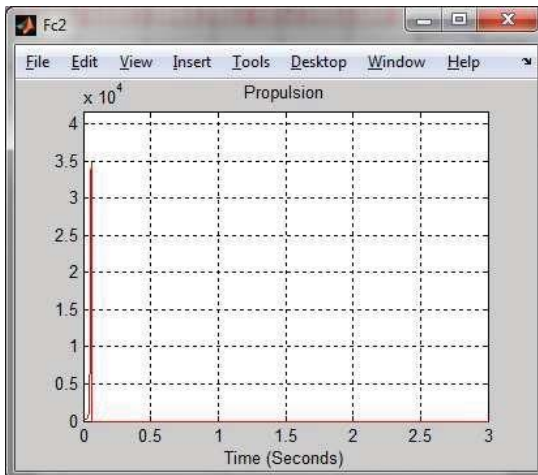

Figure 6. Contact Force between Link 2 and Link 1

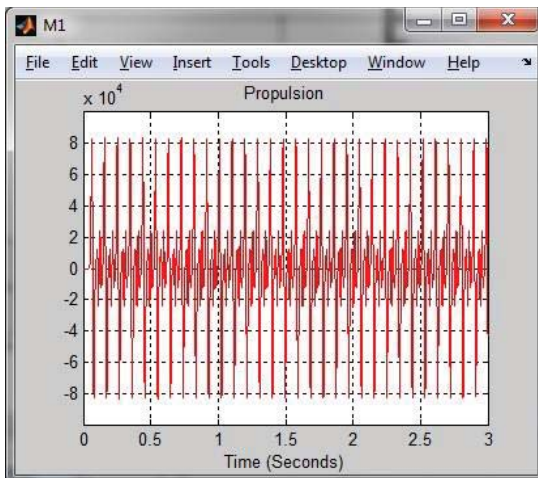
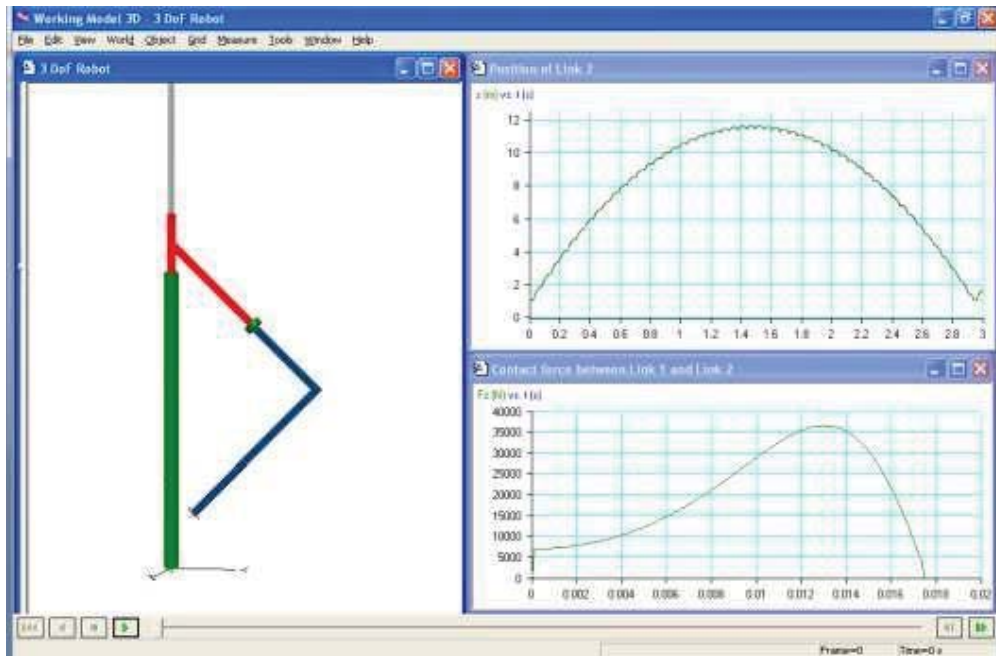

Figure 7. Joint Torque on Link 1, Motor M1.



Modeling and simulations using Working Model 3D software

Contact Force F_{c2} in the start of simulation is $245.1625N=(m_2+m_3+m_4+m_5) \cdot g$. This is reaction force of contact between Link 2 and Link 1. When Link 2 starts moving up, Contact force has its maximum and after that during movement of Link 2, no contact between Link 2 and Link 1, this mean that contact force is zero until Link 2 is coming back and strike the Link 1.

In Figure 8 is represented Contact force F_{c2} and reaction force F_{r2} (like joint 2 is rigid joint).

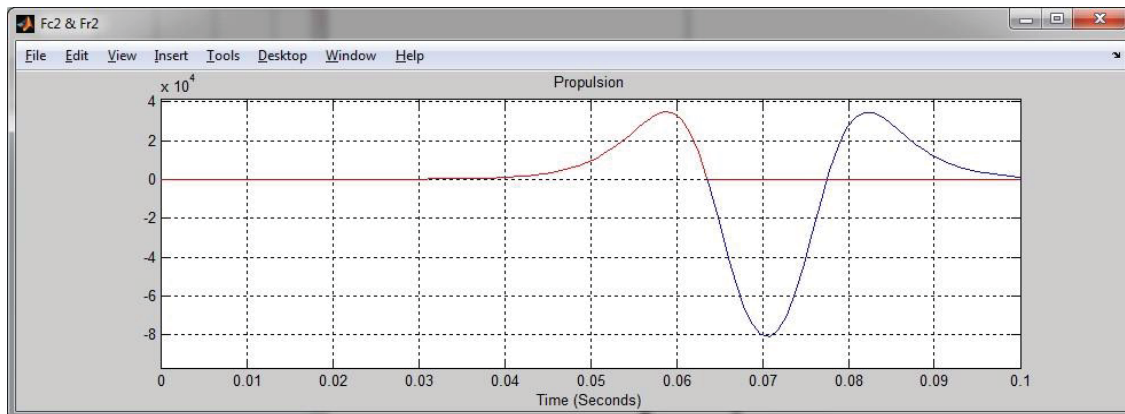

Figure 8. Contact force F_{c2} and Reaction force F_{r2}

Propulsion in this case is result of difference of **real reaction force** which is static + dynamic reaction force during movement, as is represented in Figure 2.

Conclusions

Based on simulation results for case $(q_4)_0=180^\circ$ can be concluded:

- d_2 is growing significantly from initial position 1.1m to around 11.5m.
- Link 3 oscillates around own oscillation axe.
- For this case is clear that exist propulsion effect and based on diagram of Contact Force in Figure 2 and other simulations tests which are done this is the biggest propulsion of robot.

Reference

1. Luh, J. Y. S., Walker, M. W. and Paul, R. P.; On-Line Computational Scheme for Mechanical Manipulators. *Journal of Dynamic Systems, Measurement, and Control* 102(2):69-76, June, 1980.
2. Brady, M., et al. (editors). *Robot Motion: Planning and Control*. MIT Press, Cambridge, MA, 1982.
3. Khosla, Pradeep, "*Estimation of Robot Dynamics Parameters: Theory and Application*". *Institute for Software Research*. Paper 651. <http://repository.cmu.edu/isr/651> ,Carnegie Mellon University, 1987.