

University for Business and Technology in Kosovo

UBT Knowledge Center

UBT International Conference

2017 UBT International Conference

Oct 27th, 1:00 PM - 2:30 PM

State Feedback of Complex Systems using Fuzzy Cognitive Maps

Vassiliki Mpelogianni

University of Patras, v.mpelogianni@ece.upatras.gr

Ioannis Arvanitakis

University of Patras

Peter P. Groumpos

University of Patras, groumpos@ece.upatras.gr

Follow this and additional works at: <https://knowledgecenter.ubt-uni.net/conference>



Part of the [Robotics Commons](#)

Recommended Citation

Mpelogianni, Vassiliki; Arvanitakis, Ioannis; and Groumpos, Peter P., "State Feedback of Complex Systems using Fuzzy Cognitive Maps" (2017). *UBT International Conference*. 281.

<https://knowledgecenter.ubt-uni.net/conference/2017/all-events/281>

This Event is brought to you for free and open access by the Publication and Journals at UBT Knowledge Center. It has been accepted for inclusion in UBT International Conference by an authorized administrator of UBT Knowledge Center. For more information, please contact knowledge.center@ubt-uni.net.

State Feedback of Complex Systems Using Fuzzy Cognitive Maps

Mpelogianni Vassiliki¹, Ioannis Arvanitakis² and Peter P. Groumpos³

^{1,2,3} Department of Electrical and Computer Engineering, University of Patras, Rion
26500, Greece
v.mpelogianni@ece.upatras.gr

Abstract. Complex systems have become a research area with increasing interest over the last years. The emergence of new technologies, the increase in computational power with reduced resources and cost, the integration of the physical world with computer based systems has created the possibility of significantly improving the quality of life of humans. While a significant degree of automation within these systems exists and has been provided in the past decade with examples of the smart homes and energy efficient buildings, a paradigm shift towards autonomy has been noted. The need for autonomy requires the extraction of a model; while a strict mathematical formulation usually exists for the individual subsystems, finding a complete mathematical formulation for the complex systems is a near impossible task to accomplish. For this reason, methods such as the Fuzzy Cognitive Maps (FCM) have emerged that are able to provide with a description of the complex system. The system description results from empirical observations made from experts in the related subject – integration of expert’s knowledge – that provide the required cause-effect relations between the interacting components that the FCM needs in order to be formulated. Learning methods are employed that are able to improve the formulated model based on measurements from the actual system. The FCM method, that is able to inherently integrate uncertainties, is able to provide an adequate model for the study of a complex system. With the required system model, the next step towards the development of an autonomous system is the creation of a control scheme. While FCM can provide with a system model, the system representation proves inadequate to be utilized to design classic model based controllers that require a state space or frequency domain representation. In state space representation, the state vector contains the variables of the system that can describe enough about the system to determine its future behavior in absence of external variables. Thus, within the components – the nodes of the FCM, ideally those can be identified that constitute the state vector of the system. In this work the authors propose the creation of a state feedback control law of complex systems via Fuzzy Cognitive Maps. Given the FCM representation of a system, initially the components-states of the system are identified. Given the identified states, a FCM representation of the controller occurs where the controller parameters are the weights of the cause-effect relations of the system. The FCM of the system then is augmented with the FCM of the controller. An example of the proposed methodology is given via the use of the cartpendulum system, a common benchmark system for testing the efficiency of control systems.

s

Keywords: complex dynamic systems, feedback control, fuzzy cognitive maps

Complex Systems

"Complex Systems" is the new approach to science studying how relationships between parts give rise to the collective behaviors of a system, and how the system interacts and forms relationships with its environment. Social systems formed (in part) out of relationships between people, the brain formed out of neurons, molecules formed out of atoms, the weather formed out

of air flows are all examples of complex systems. Studying complex systems cuts across all of science, as well as engineering, management, and medicine. It is also relevant to art, history, literature and other humanities. It focuses on certain questions about relationships and how they make parts into wholes. These questions are relevant to all systems that we care about. There are three interrelated approaches to the modern study of complex systems: [1]

- (1) How interactions give rise to patterns of behavior; meaning the patterns that emerge from the interactions that exist between the systems components
- (2) The space of possibilities of describing a system; regarding on one hand its complexity and on the other hand the observer how undertakes the task to describe a system
- (3) The formation of complex systems through pattern formation and evolution; apart from the patterns that exist between the components of a system there is also the way a system evolves through time and the ways such an evolution can change the way it operates and ultimately its description.

However, the common question with complex systems is not only how we can study them but also how we can control them.

State Feedback Control Method

A common methodology of mathematically describing a complex dynamic system is the state space representation. For discrete linear time-invariant systems the standard state space approach goes as follows:

$$\begin{aligned}x_{k+1} &= Ax_k + Bu_k \\y_k &= Cx_k + Du_k\end{aligned}\tag{1}$$

Where x is the vector of state variables, u is the input vector, y is the output vector, A is the system matrix, B is the input matrix, C is the output matrix and D is the feed forward matrix.

In order to design a control methodology for such a system one of the most common methodologies is the state feedback methodology. State feedback (FSF), or pole placement, is a method employed in feedback control system theory to place the closed-loop poles of a plant in pre-determined locations in the s -plane[2]. Placing poles is desirable because the location of the poles corresponds directly to the eigenvalues of the system (matrix A), which control the characteristics of the response of the system. Given the representation of a system from Eq.1 then the poles of the system transfer function are the roots of the characteristic equation given by

$$|sI - A| = 0$$

Full state feedback is utilized by commanding the input vector u . Consider an input proportional to the state vector

$$u = -Kx$$

Then the state feedback of a system can be described from the following figure.

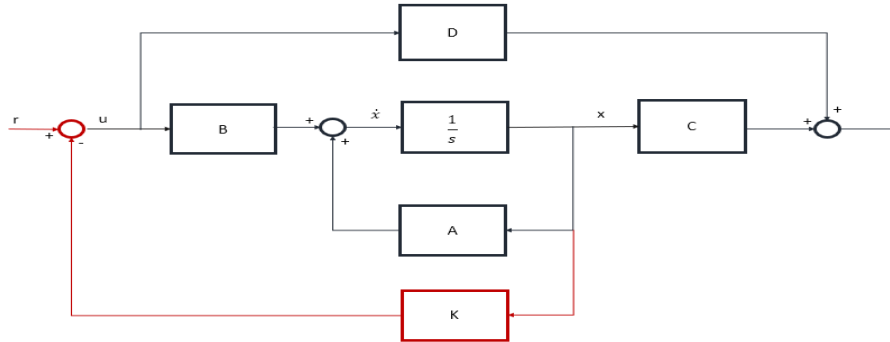

Figure 3: State feedback control scheme

There are many methodologies of computing vector K . In this paper we will study the possibility of calculating the values of the feedback controller from a fuzzy cognitive map.

Fuzzy Cognitive Maps for Modelling Complex Systems

Fuzzy Cognitive Maps (FCM) constitute a computational methodology that can examine situations during which the human thinking process involves fuzzy or uncertain descriptions. A FCM presents a graphical representation through a signed directed graph with feedback consisting of nodes and weighted arcs [3]. The nodes of the graph stand for concepts that are used to describe, via cause and effect, the relations and behavior of a system in a simple and symbolic way. They are connected by signed and weighted arcs which represent the causal relationships that exist between the concepts (Fig. 1). Each concept, C_i (variable), is characterized by a number that represents its value and is calculated through the transformation of a fuzzy value to the interval $[0,1]$. The values of the interconnections', weights, are initially linguistically defined by experts and then transformed into values which belong to the interval $[-1,1]$ through a specially designed algorithm [4]. In this way FCMs embody the accumulated knowledge and experience from experts who know how the system behaves in different circumstances.

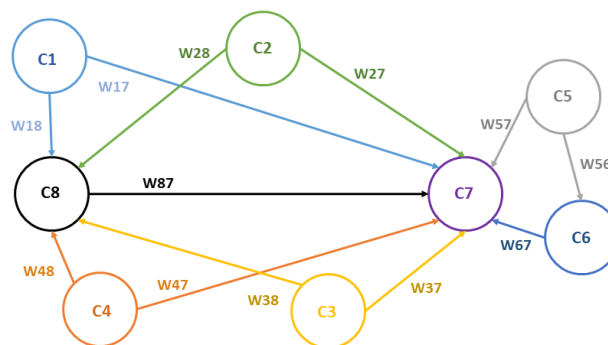

Figure 4: Fuzzy Cognitive Map

The sign of each weight represents the type of influence between concepts. There are three types of interconnections between two concepts C_i and C_j :

- $W_{ij} > 0$, an increase or decrease in C_i causes the same result in concept C_j .

- $W_{ij} < 0$, an increase or decrease in C_i causes the opposite result in C_j
- $W_{ij} = 0$, there is no interaction between concepts C_i and C_j

The degree of influence between the two concepts is indicated by the absolute value of W_{ij} . During the simulation, the value of each concept (A_i) is calculated using the following rule:

$$A_i(k + 1) = f(A_i(k) + \sum_{j=1, j \neq i}^n A_j(k)w_{ji}) \quad (2)$$

Where k represents the iteration step, n is the number of concepts and f is the sigmoid function given by the following equation:

$$\frac{1}{1 + e^{-\lambda x}} \quad (3)$$

Where $\lambda > 0$ determines the steepness of function f .

The FCMs' concepts are given some initial values. Then the values of the concepts are calculated using Equation 1. This iterative process ends when a steady state is achieved; the concepts' values converge to a single value [5]-[7].

Fuzzy Cognitive Maps as a Control Design Methodology

Complex processes are characterized by high dimension, comprised of subsystems that are strongly interconnected and mutually dependent. For such systems soft computing modeling techniques are proposed to address uncertainty issues. A large number of complex processes are not well understood and their operation is "tuned" by experience rather than through the application of pure mathematic principles. Our goal is to be able to combine experience with mathematic principles in order to effectively and efficiently control complex systems. For this reason, we propose to use a Fuzzy Cognitive Map to calculate the weights of the vector K of a feedback controller. To make this possible we have to design a FCM with input concepts the states of the system and output concepts the inputs of the system. Through learning processes the weights of the FCM will be adjusted to give the correct cause and effect relationships between the concepts. These weights will then be translated into the values of K matrix of the feedback controller. In the following figure there is an overview of the proposed system.

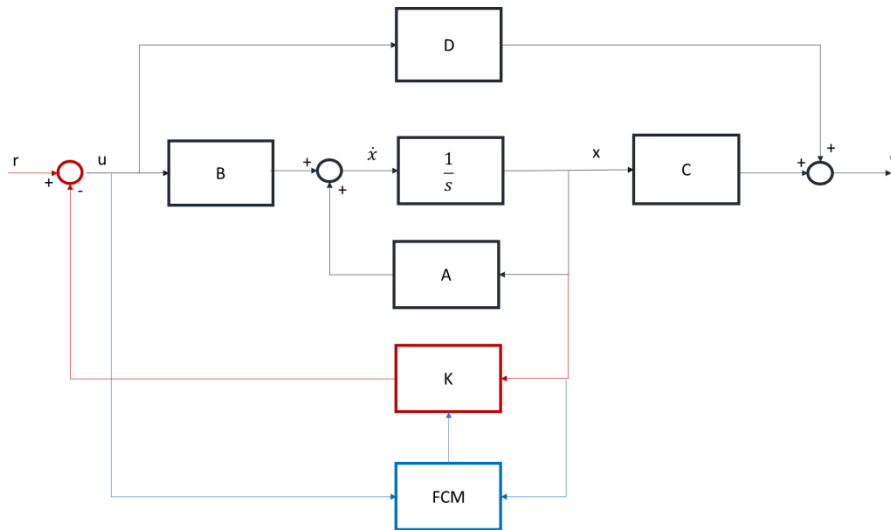

Figure 5: State Feedback Control with Closing Remarks

Today's systems are complex and they are usually comprised of a large number of interacting and coupling entities that are called subsystems and/or components. These systems have nonlinear behavior and cannot simply be derived from summation of analyzed individual component behavior. In the case of complex dynamical systems, conventional modeling and controlling methods have a limited contribution. The modeling of complex systems requires new methods that can utilize the existing knowledge and human experience. Furthermore, these methods are equipped with sophisticated characteristics such as failure detection, optimization and identification qualities. Such a method is the soft computing methodology of fuzzy cognitive map (FCM) which has been improved and enhanced using a new construction algorithm, and is implemented for modeling complex systems. However, today's FCM theories have a good number of drawbacks.

In addition, FCM have not been used for controlling complex dynamic systems. There are almost no studies investigating feedback control of complex dynamic systems using FCM. This paper is probably the first attempt to address this very challenging and critical issue. For the first time a control design methodology for

complex dynamic systems have been proposed here. Early simulation studies show that the proposed methodology is very promising. These results have not been yet examined and verified as the state feedback problem requires. Soon these results will be verified and will be presented on next year's conferences. We hope to present these results at next conference of UBT in Durres in 2018.

References

1. Bar-Yam, Y. (2002). General features of complex systems. *Encyclopedia of Life Support Systems (EOLSS)*, UNESCO, EOLSS Publishers, Oxford, UK.
2. Ogata, K., & Yang, Y. (1970). Modern control engineering.

3. Groumpos, P.P. and Stylios, C.D. (2000). Modelling supervisory control systems using fuzzy cognitive maps. *Chaos, Solitons & Fractals*, 11(1), 329-336.
4. Groumpos, P.P. (2010). Fuzzy cognitive maps: Basic theories and their application to complex systems. In *Fuzzy cognitive maps*, 1-22. Springer.
5. Anninou, A.P., Groumpos, P.P., and Panagiotis, P. (2013). Modeling health diseases using competitive fuzzy cognitive maps. In *IFIP International Conference on Artificial Intelligence Applications and Innovations*, 88-95. Springer.
6. Axelrode, R. (1976). The analysis of cognitive maps. *Structure of Decision.*, 55-73.
7. Papageorgiou, E. and Stylios, C. (2008). Fuzzy cognitive maps. *Handbook of Granular Computing*, 755-774