

University for Business and Technology in Kosovo

UBT Knowledge Center

UBT International Conference

2015 UBT International Conference

Nov 7th, 9:00 AM - 5:00 PM

10 W DC-DC converter based LED driver circuit design

Ö. Faruk Farsakoğlu

Aralık University, ffarsakoglu@kilis.edu.tr

H. Yusuf Hasrici

Aralık University

Ibrahim Çelik

Aralık University

Follow this and additional works at: <https://knowledgecenter.ubt-uni.net/conference>



Part of the [Computer Sciences Commons](#), and the [Digital Communications and Networking Commons](#)

Recommended Citation

Farsakoğlu, Ö. Faruk; Hasrici, H. Yusuf; and Çelik, Ibrahim, "10 W DC-DC converter based LED driver circuit design" (2015). *UBT International Conference*. 99.

<https://knowledgecenter.ubt-uni.net/conference/2015/all-events/99>

This Event is brought to you for free and open access by the Publication and Journals at UBT Knowledge Center. It has been accepted for inclusion in UBT International Conference by an authorized administrator of UBT Knowledge Center. For more information, please contact knowledge.center@ubt-uni.net.

10 W DC-DC converter based LED driver circuit design

Ö. Faruk Farsakoğlu¹, H. Yusuf Hasirci¹, İbrahim Çelik¹

¹Kilis 7 Aralık University, Department of Electrical and Electronic Engineering, Kilis, 79000
ffarsakoglu@kilis.edu.tr

Abstract. Considering the total amount of energy consumed in the world, energy used in lighting is of utmost importance. For this reason, systems used in lighting should be energy efficient, and more efficient lighting elements should be preferred. LED, as a solid-state lighting system, is more energy efficient than the lighting systems with conventional lighting elements. Some of the LEDs used in solid-state lighting systems are named as standard 5mm LEDs and power LEDs. Because power LEDs have more light efficiency than standard 5 mm LEDs, they are produced as an alternative to conventional light sources. Power LEDs draw much more current than standard 5 mm LEDs. LEDs need LED drivers that provide them with constant current to run efficiently, and have a long life. The present research studies 10 W DC-DC converter based current limited LED driver circuits. Simulations were created for these LED driver circuits, and they are analysed through their simulations. Efficiency, input current, total circuit loss, output current and power values are measured. In this context, output current and efficiency values of the driver circuits are analysed in terms of energy efficiency, and optimised in accordance with energy efficiency.

Keywords: Current limited LED driver, energy efficiency, power LED, DC-DC converter

1. Introduction

Considering that, one fifth of the energy consumed in the world is used for lighting, saving of the energy used in lighting systems, and increasing the efficiency of this energy becomes inevitable [1]. The most important factor in energy saving is energy conservation. The elements used in lighting (light source, secondary elements etc.) should be chosen among systems running correctly and efficiently for a better saving, and more efficient use of energy. Solid-state Lighting (SSL) systems can conserve energy more than conventional lighting systems. Additionally, SSL systems can be an alternative technology to develop lighting systems. Fig. 1 presents the efficiency of some LEDs and conventional lighting systems. Solid-state lighting technology is based on the use of light emitting diodes (LED) [2]. The first solid-state lamps were used in display LED applications [3].

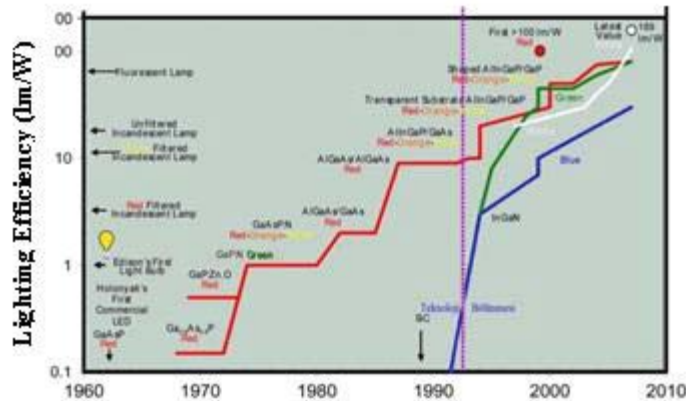
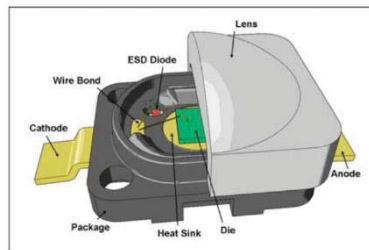

Fig.0. Efficiency values for some solid-state LEDs [4]

Semi-conductive LED lighting elements are produced as power LEDs as a better alternative to conventional lighting elements such as incandescent lamp, fluorescent tubes, and halogen lamps due to their many advantages such as higher energy efficiency, longer life (50,000 – 100,000 hours), needing less maintenance, smaller equipment size, and therefore smaller size, variety in light and colour, endurance to impact and vibrations, and less energy consumption. Power LEDs are commonly used in lighting sector due their high lumen values. A schematic diagram of LEDs is presented in Fig. 2. Current values of power LEDs are much higher than standard 5mm LEDs. If these LEDs are to be used, they need a special type of driver circuit.

**Fig. 2.** Schematic diagram of power LEDs [5]

2. LED Driver Circuits

LEDs need driver circuits as they can only run on DC voltage polarity, and need current limiting [6]. LEDs can be divided into two groups as; current limited and voltage limited. Current limited LED driver circuits are generally preferred, as overcurrent results in heating in LEDs. Various current driving methods are studied in terms of energy efficiency. Some of these are; LED driver circuits with LM317 regulator circuit, simple driver circuits with resistance, and DC-DC convertor based LED driver circuits. Driver circuits with LM317 integrated circuit can be used within 1.25V and 37V input voltage range, and up to 1.5A output current [7]. LM317 is not suitable for high power LED drivers. As presented in Figure 5, output voltage is kept constant with resistance attached to adjust ends. Around 4-5 W of energy is lost in the LM317 used in this driver, when the circuit is in transmission. This decreased the efficiency of afore mentioned driver circuit. In the simple driver circuit with resistance, 0.7 A of current is transmitted when energy is first given to the circuit. In time, LEDs start to heat, and forward voltage of LEDs start to decrease. The current transmitted on the circuit increases in this case, and when the heat reaches to a certain extent, current applied to LED increases to 0.75 A. Increased current results in more heating, and LED can be broken in time without necessary precautions.

2.1 DC - DC Convertor Based LED Driver Circuit

10 W DC-DC convertor based current limited LED driver circuit was designed using LM3429 dropper-amplifier regulator. Fig. 3 presents a 10 W DC-DC convertor based current limited LED driver circuit. This regulator can run up to 75 V input voltage, and comply with dropper, amplifier, dropper-amplifier circuit topologies.

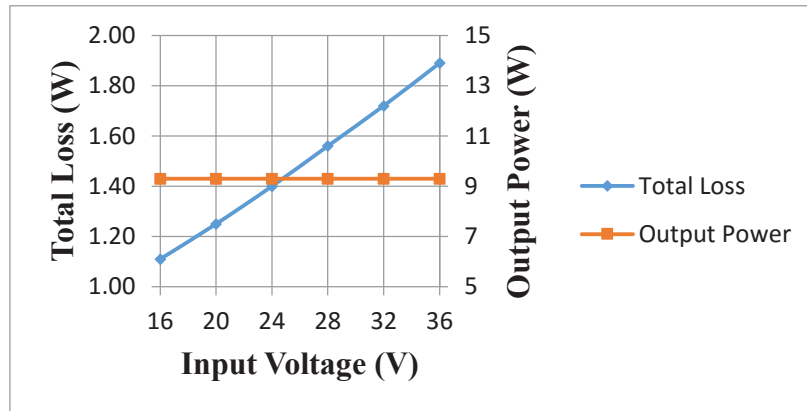

Fig. 5. Change in output power and total loss of 10W DC-DC convertor based LED driver circuit according to input voltage

Change in input and output current of 10W DC-DC convertor based LED driver circuit according to input voltage is presented in Fig. 6. Accordingly, as input voltage value increases, input current decreases, and LED current doesn't change.

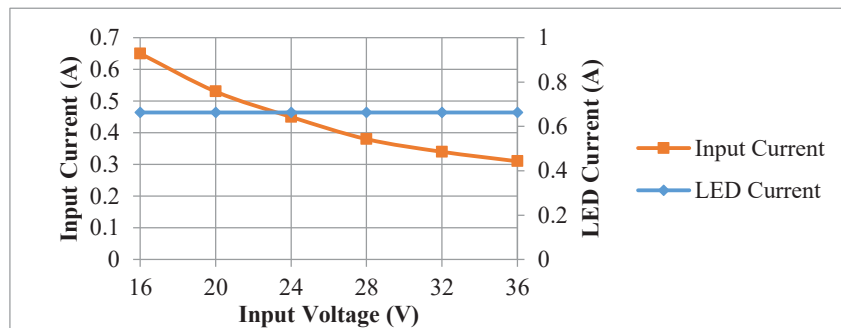

Fig.6. Change in input and output current of 10W DC-DC convertor based LED driver circuit according to input voltage

Conclusion

DC-DC convertor (buck) based current limited LED driver circuit was designed as 10W, and simulations were created. Input current, LED current (output current), efficiency, output power, and total loss values were measured for DC-DC convertor (buck) based current limited LED driver circuit. It was observed that, as input voltage increased, efficiency decreased accordingly. It was also found that output power didn't change according to input voltage in DC-DC convertor (buck) based current limited LED driver circuit. Energy spent by LEDs didn't change according to input voltage, while total loss increased. As input voltage increased, LED current increased as well, while input current of the circuit decreased. It was found that, 10W DC-DC convertor (buck) based current limited LED drivers were more efficient than simple driver circuits with one resistance, and LED driver circuit with LM117 regulator.

References

- 1 Enerji ve Tabii Kaynaklar Bakanlığı, Kamuda Verimli Aydınlatmaya Geçiş, Ocak 2009, Ankara, http://www.enerji.gov.tr/File/?_path = ROOT%2F1%2FDocuments%2FBelge%2FKVAG Raporu. pdf,
- 2 Perpifiai, X., Werkhoven, R. J., Vellvehi, M., Jordai, X., Kunen, J. M., Jakovenk, J., Bancken P. and Bolt, P.: LED Driver Thermal Design Considerations for SolidStateIEEE, 978-1-4673-1513-51121, (2012) 1-5,
- 3 Arik, M., Petrosk J., and Weavery, S. Thermal Challanges In The Future Generation Solid State Lighting Applications, IEEE, 0-7803-7152-6/02 (2002), 113-120
- 4 Dupuis R. D. and Krames,M. R, History, Development and Applications of High-Brightness Visible Light-Emitting Diodes,Journal of Light wave Technology, Vol. 26, (2008)1154-1171
- 5 PowerLED nedir?, <http://www.ledportali.com/powerled-nedir/> (2015)
- 6 Gürbüz, Y. Güç Faktörü Düzeltmeli Güç LED Sürücü Tasarımı ve Gerçekleştirilmesi, Selçuk Üniversitesi Fen Bilimleri Enstitüsü, Konya (2012)
- 7 LM317 Datasheet, <http://www.ti.com/lit/ds/symlink/lm317.pdf>